

标准直轴

机座号: 60 80 100 130



型号/参数/配置



机座号	减速比	型号	适配伺服电机主参数				伺服减速机主参数				
			机座号	轴径	额定转速 r/min	额定转矩 N·m	额定功率 kW	输出转速 r/min	输出转矩 N·m	背隙 arcmin	转动惯量 ×10 ⁻⁴ kg·m ²
60	1:5	60GB5HT	60	Φ14	3000	0.64	0.2	600	2.9	5	10
						1.3	0.4	600	5.8		10
	1:10	60GB10HT				0.64	0.2	300	5.8		5
80	1:5	80GB5HT	80	Φ19	3000	2.4	0.75	600	10.8	5	30
						2.4	0.75	300	21.6		15
	1:25	80GB25HT	60	Φ14	3000	0.64	0.2	120	13.6	7	12
100	1:5	100GB5HT	100	Φ24	3000	3.2	1	600	14.4	5	60
						4.8	1.5	600	21.6		60
	1:10	100GB10HT				3.2	1	300	28.8		30
						4.8	1.5	300	43.2		30
	1:25	100GB25HT	80	Φ19	3000	2.4	0.75	120	51	7	20
	1:50	100GB50HT	60	Φ14	3000	1.3	0.4	60	55.2	8	10
130	1:5	130GB5HT	130	Φ24	1500	6.4	1	300	28.8	5	200
						9.6	1.5	300	43.2		200
						12.7	2	300	57.2		200
						19.1	3	300	86		200
	1:10	130GB10HT	130	Φ24	1500	6.4	1	150	57.6	5	100
						9.6	1.5	150	86.4		100
	1:25	130GB25HT	100	Φ24	3000	4.8	1.5	120	102	7	40
	1:50	130GB50HT	80	Φ19	3000	2.4	0.75	60	102	8	20

● 减速比 1:5、1:10 传动效率 90%，1:25、1:50 传动效率85%

■ **外形图** 带*号的尺寸为与伺服电机对接的尺寸，若图中标准对接尺寸无法满足设计要求，请联系我司非标定制。

型号：60GB5HT 60GB10HT

质量：1.4kg

CAD 60GBHT01

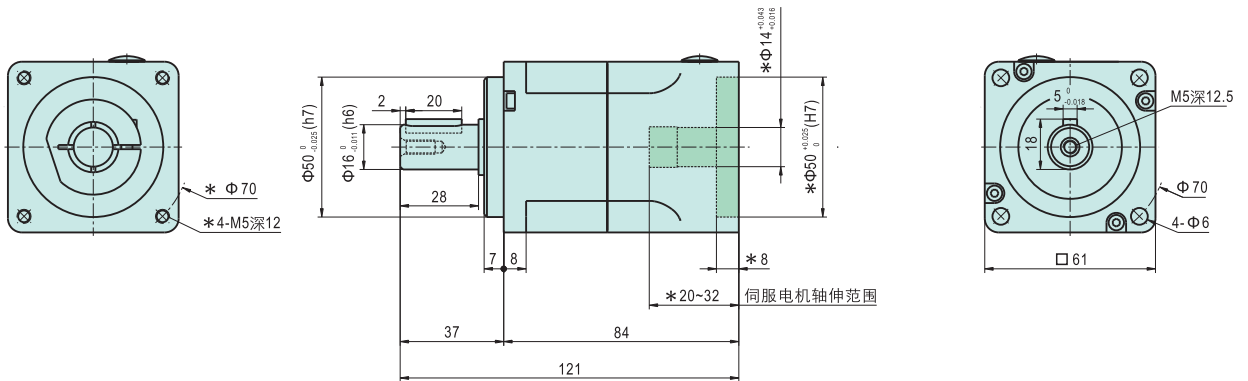

型号：80GB5HT 80GB10HT

质量：3kg

CAD 80GBHT01

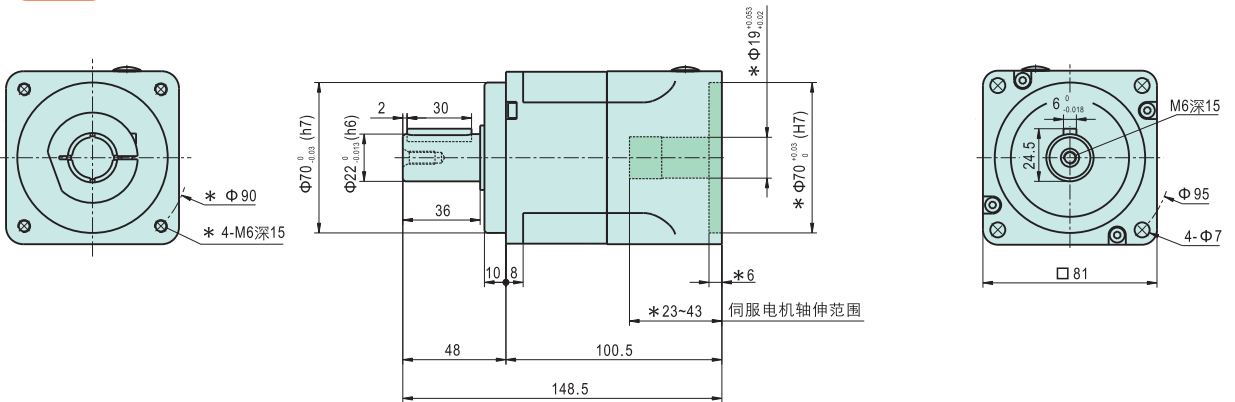

型号：80GB25HT

质量：3.8kg

CAD 80GBHT02

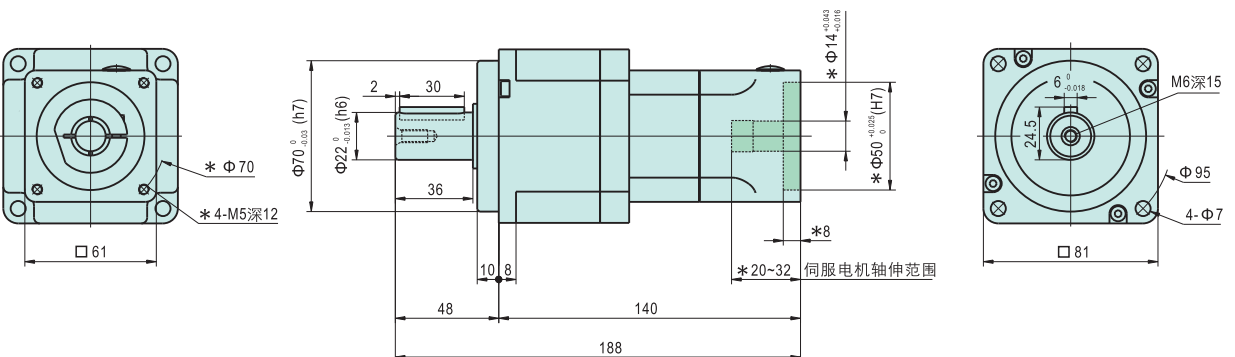

伺服减速机

■ **外形图** 带*号的尺寸为与伺服电机对接的尺寸，若图中标准对接尺寸无法满足设计要求，请联系我司非标定制。

型号：100GB5HT 100GB10HT

质量：5.8kg

CAD 100GBHT01

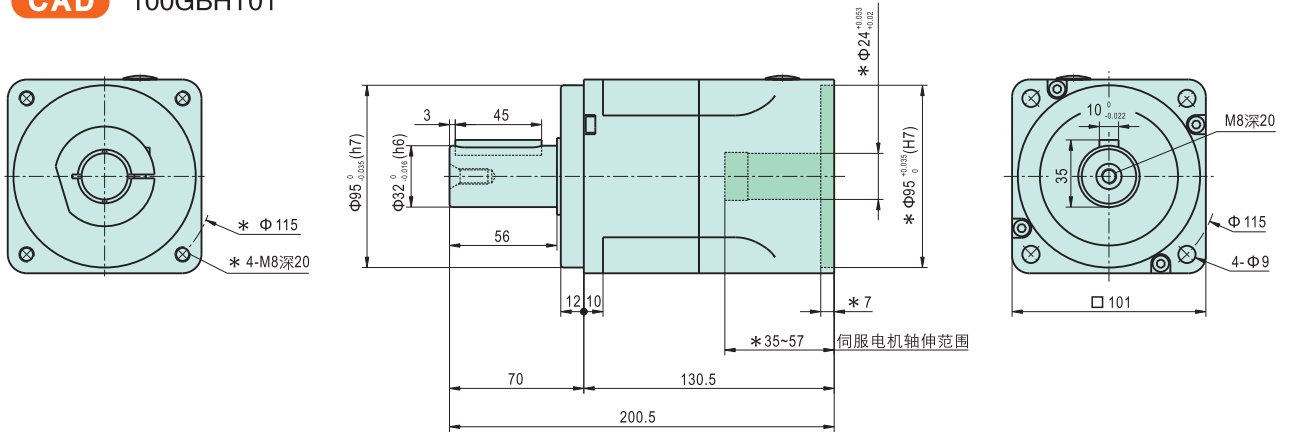

型号：100GB25HT

质量：7.7kg

CAD 100GBHT02

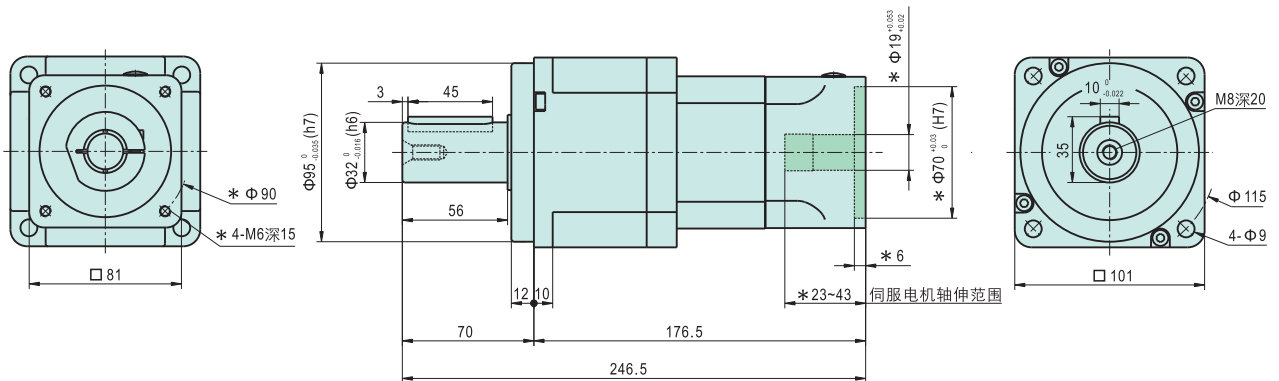

型号：100GB50HT

质量：6.2kg

CAD 100GBHT03

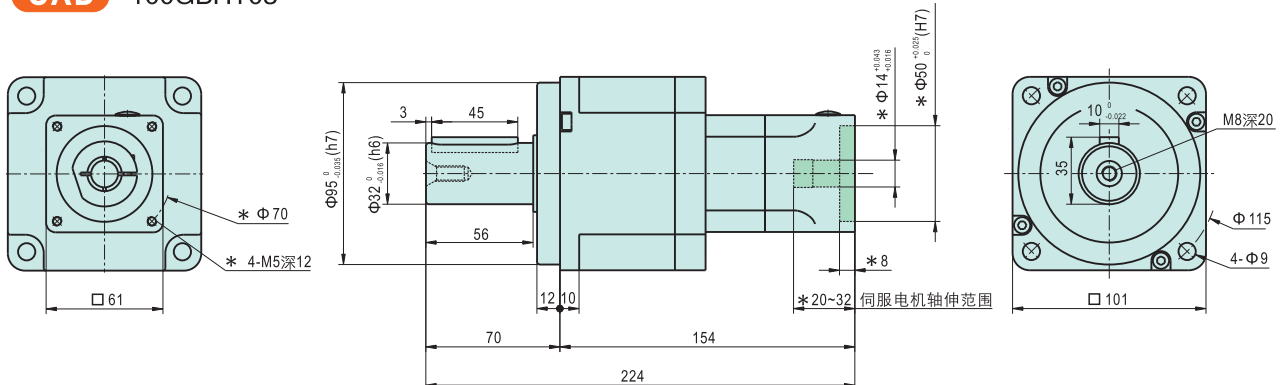

■ **外形图** 带*号的尺寸为与伺服电机对接的尺寸，若图中标准对接尺寸无法满足设计要求，请联系我司非标定制。

型号: 130GB5HT 130GB10HT

质量: 10.8kg

CAD 130GBHT01

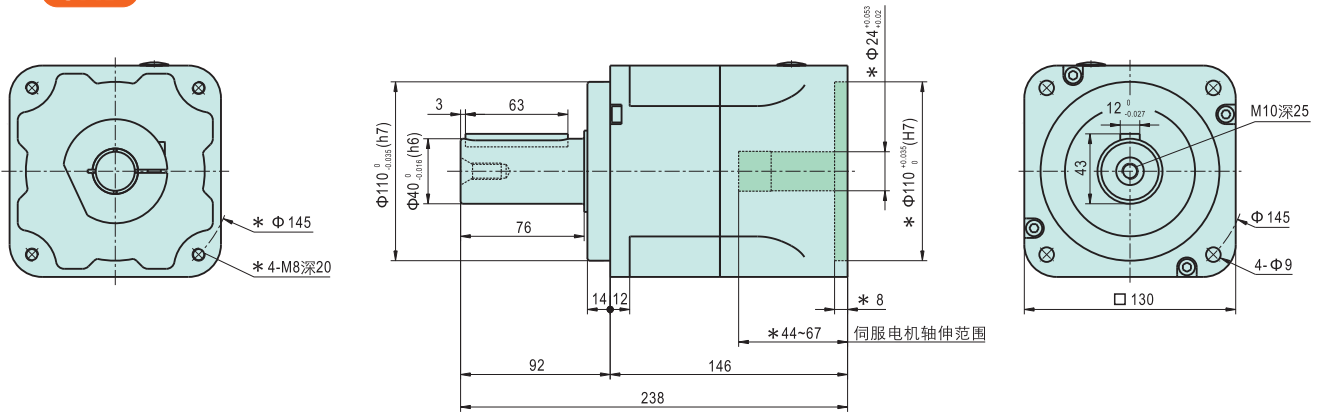

型号: 130GB25HT

质量: 14.5kg

CAD 130GBHT02

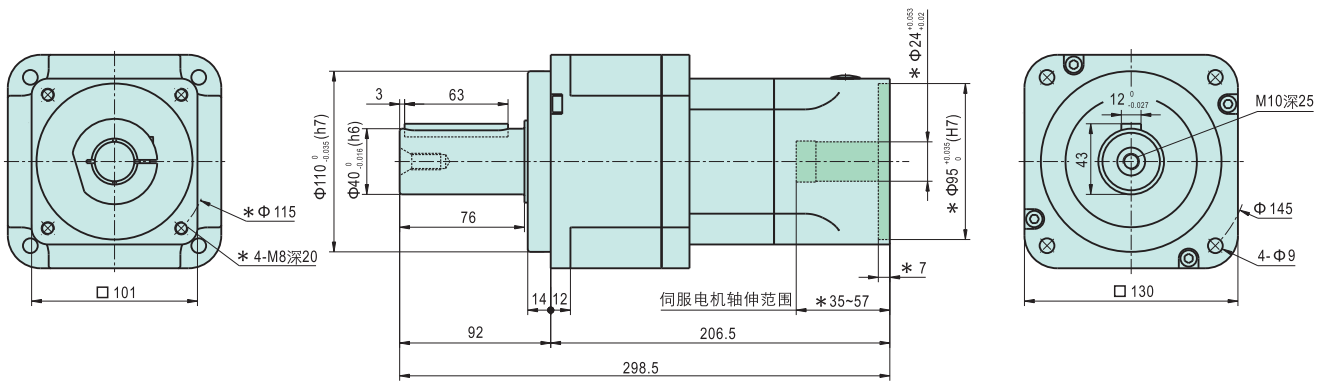

型号: 130GB50HT

质量: 12.6kg

CAD 130GBHT03

